

■ Overview

This document is the application notes about the design of 2EG series.

The example of application circuits and parts value which are indicated to this application note aim at assistance of a design.

Therefore, external parts variation or user operating conditions are not fully taken into consideration.

Please take parts variation, operating conditions into consideration when designing.

Contents

- 1. Application Examples ----- 2
  - 1.1 Si-IGBT <Direct mode> ----- 2
  - 1.2 Si-IGBT <Half bridge mode> ----- 2
  - 1.3 SiC-MOSFET <Direct mode> ----- 3
  - 1.4 SiC-MOSFET <Half bridge mode> ----- 3
- 2. Pin Functions and Descriptions ----- 4
  - 2.1 Pin Functions ----- 4
  - 2.2 Description ----- 6
- 3. Product Connection Instructions, Ambient Environment Instructions, Usage Cautions ----- 8
  - 3.1 Abnormal input current protection ----- 8
  - 3.2 VIN- and GND ----- 8
  - 3.3 Power ON / OFF sequence (VIN+, VCC) ----- 8
  - 3.4 Mechanical switch ----- 8
  - 3.5 Input signals ----- 9
  - 3.6 Input cables ----- 9
  - 3.7 Half bridge mode ----- 9
  - 3.8 Gate resistors selection method ----- 10
  - 3.9 NTC pin ----- 11
  - 3.10 Product mounting instructions ----- 11
  - 3.11 Handling ----- 12
  - 3.12 Device short circuit ----- 12
  - 3.13 Ambient temperature instructions ----- 12

## 1. Application Examples

### 1.1 Si-IGBT <Direct mode>

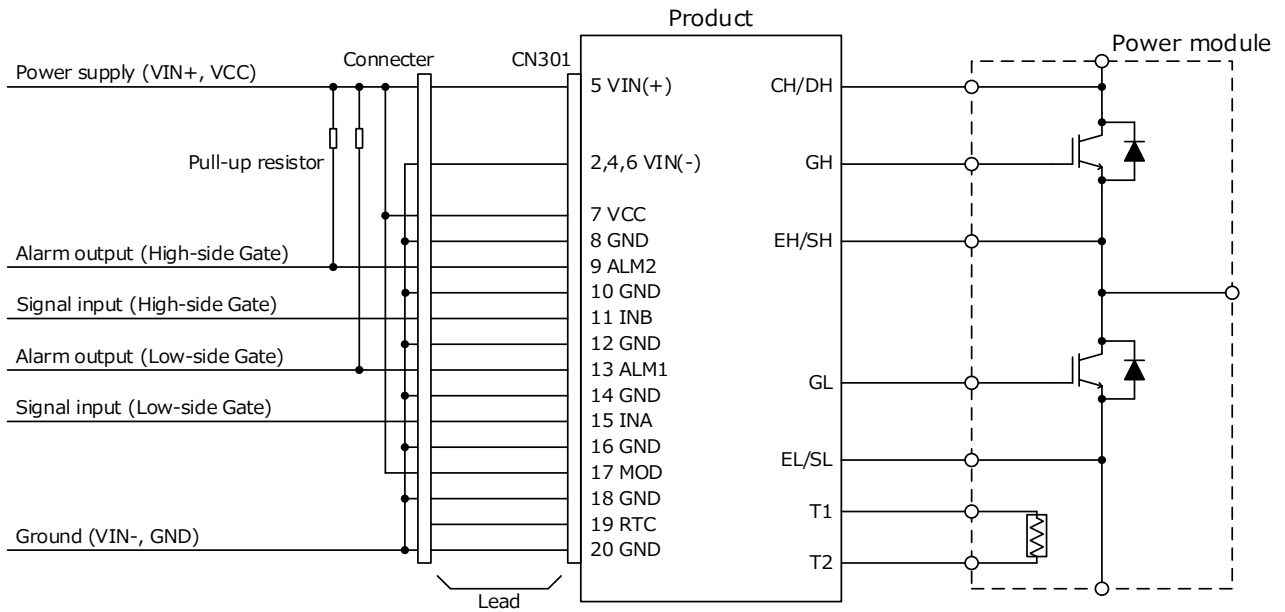

### 1.2 Si-IGBT <Half bridge mode>

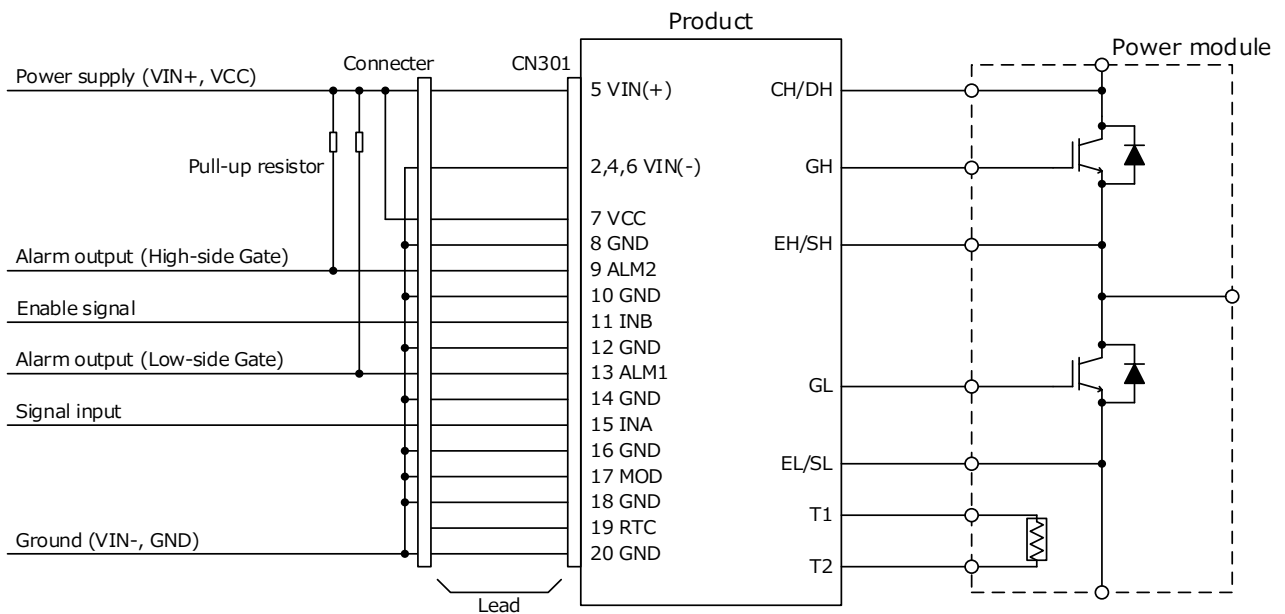

1.3 SiC-MOSFET <Direct mode>

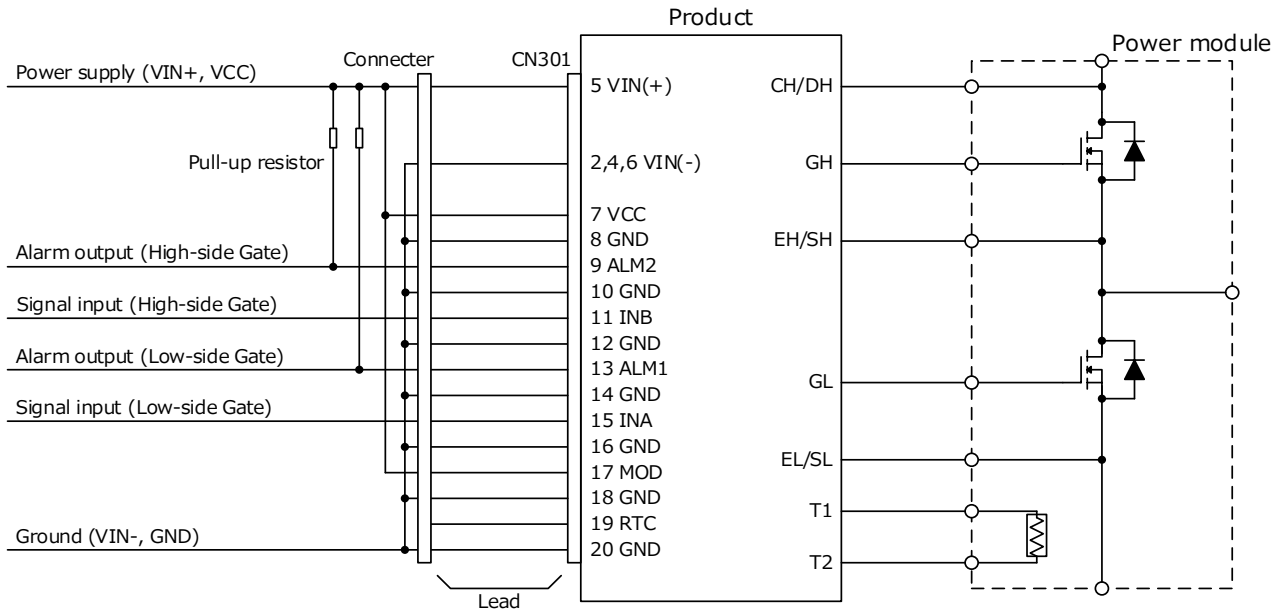

1.4 SiC-MOSFET <Half bridge mode>

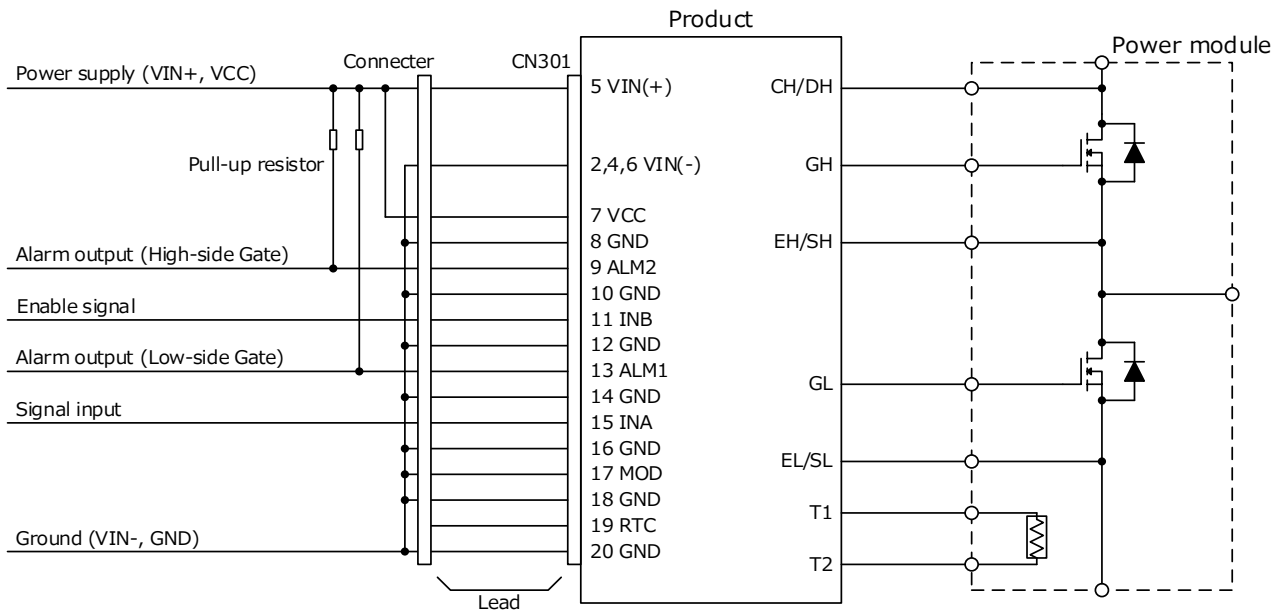

## 2. Pin Functions and Descriptions

### 2.1 Pin Functions

(1) VIN(+), VIN(-) (Power supply pin for DC/DC converter)

(2) VCC (Power supply pin for drive circuit)

(3) GND (Ground pin for drive circuit)

(4) MOD, INA, INB (Mode switching pin, Control input pin)

The INA, INB and MOD pin is a pin used to determine output logic.

Direct mode / Half bridge mode can be switched by MOD pin.

In Half bridge mode, it functions as INA: gate signal, INB: enable signal.

At start up, please INA and INB pin is Low.

MOD	INB	INA	GH	GL	Mode
H (Floating or Connected to VCC)	X	L	X	L	Direct mode
	X	H	X	H	
	L	X	L	X	
	H	X	H	X	
L (Connected to GND)	L	X	L	L	Half bridge mode
	H	L	H	L	
	H	H	L	H	

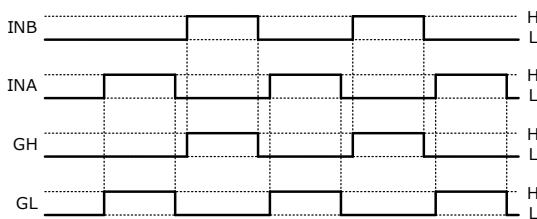

Timing chart of Direct mode

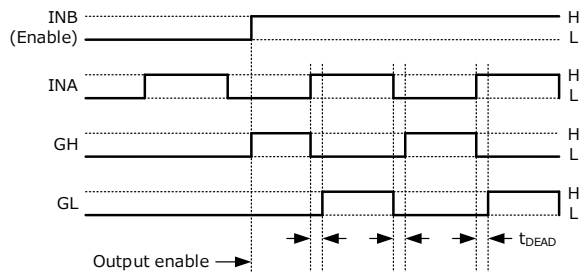

Timing chart of Half bridge mode

(5) ALM1,2 (Alarm signal output pin)

When abnormality occurs (UVLO, short circuit detected), This pin outputs an alarm signal. (Open drain)

Status	ALM1,2
While in normal operation	Hi-Z
UVLO, When detecting short circuit, When Gate-Emitter short circuit	L

When using this function, connect a pull-up resistor because it is an open drain output.

Pull-up voltage [V]	Pull-up resistor [kΩ]
5	4.7
15	15

(6) RTC (Restart time of protection circuit control pin)

The RTC pin can be used to adjust the restart time from the protected state (UVLO, short circuit detection).

When this pin is open, the restart time is set to 110ms(typ).

The restart time can be adjusted within the following range by the resistance or voltage connected to the RTC pin.

① Adjustment by resistor

The restart time can be adjusted by adding a resistor between RTC and GND.

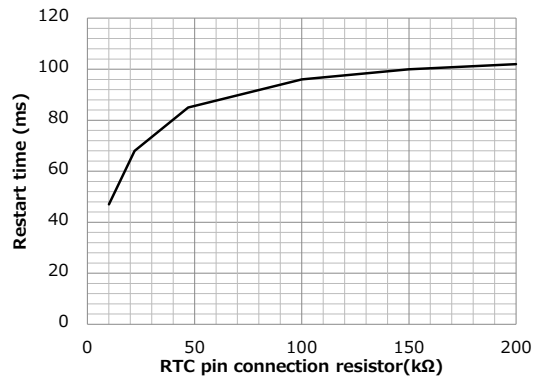
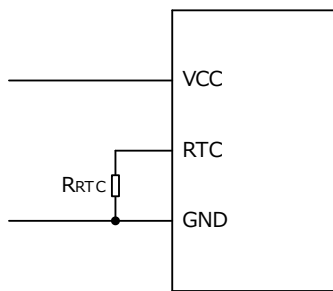

② Adjustment by voltage

The restart time can be adjusted by applying a voltage between RTC and GND.

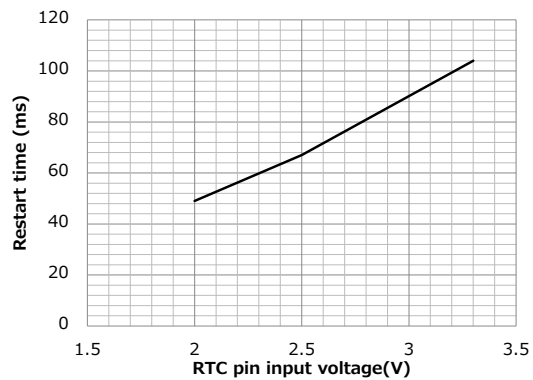
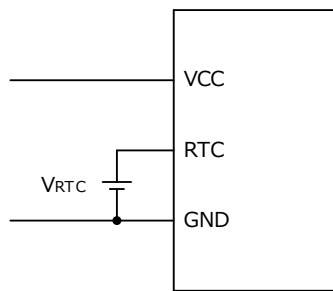

2.2 Description

(1) Overload protection function (DC / DC converter)

The overload protection function is protection when an output short circuit or overload occurs.

The operation mode is automatic reset operation.

Do not use beyond the maximum output power or permissible frequency curve as it may cause the gate voltage to drop.

(2) Overheat protection (DC / DC converter)

This module has an overheat protection function to prevent damage and smoke even if the module overheats for some reason.

The operation mode is automatic reset operation.

Operation is auto restored when the internal temperature of the module becomes normal.

(3) Undervoltage Lockout (UVLO) function

The control circuit incorporates the undervoltage lockout (UVLO) function on the OUT(H) sides.

When the OUT(H) voltage drops to the UVLO ON voltage, the Output pin and the ALM pin both will output the "L" signal.

When the OUT(H) voltage rises to the UVLO OFF voltage, these pins will be reset.

(4) Short circuit protection function, Soft turn-off function

When the collector pin voltage exceeds VSD, the short circuit protection function will be activated.

When the short circuit protection function is activated, the OUT pin voltage will be set to the "L" level,

and then the ALM pin voltage to the "L" level.

Also, soft turn-off function works to reduce collector voltage surge due to short circuit current.

Short-circuit protection is canceled automatically after an abnormal condition restart time and when the input signal is "L" level.

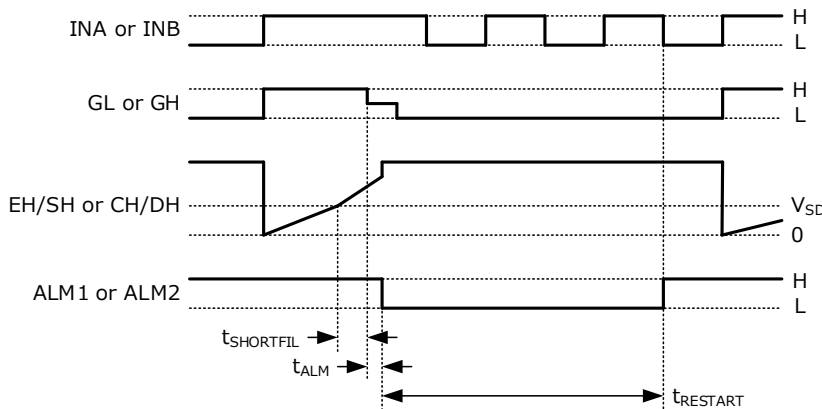

Timing chart of short circuit protection function

(5) Miller clamp function (Option)

If OUT=L and the Gate voltage <  $V_{CLPON}$ , the internal MOSFET for miller clamp turns on.

OUT	Gate voltage	Internal MOSFET for miller clamp
H	X	OFF
L	Not less than $V_{CLPON}$	OFF
L	Less than $V_{CLPON}$	ON

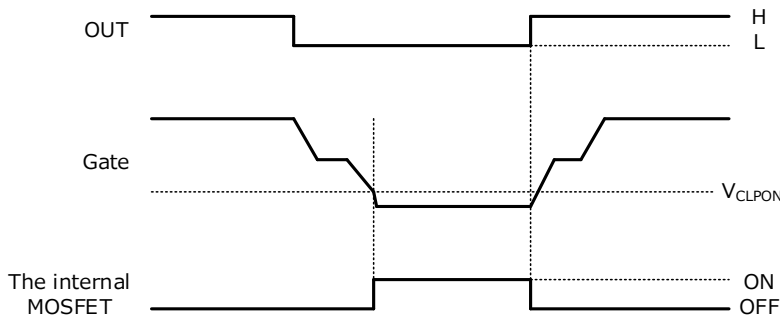

Timing chart of Miller clamp function

(6) Active clamp function (Option)

The active clamp function protects the IGBT from a sudden voltage surge between the collector and emitter that occurs when the IGBT is turned off. Depending on the DC-LINK voltage and surge voltage, the losses that occur in TVS diodes and IGBTs increase. If a high surge voltage is clamped continuously, stress will be applied to the driver and IGBT. Therefore, the main circuit conditions (DC-LINK voltage, parasitic inductance,  $dI_c / dt$ ) should be optimized and designed so that the active clamp function does not operate in normal status. Design the TVS surface temperature not to exceed 120 °C under any conditions.

When the collector-gate voltage exceeds the breakdown voltage of the active clamp TVS diode, current flows from the collector to the gate. The current ( $I_{tvs}$ ) supplies the gate with charge, partially turning on the IGBT and clamping the collector voltage. TVS loss can be obtained by time integration of the current ( $I_{tvs}$ ) and collector-emitter voltage ( $V_{ce}$ ).

To strengthen the clamp, the gate may rise even during the period when no current is flowing through the TVS diode, but this is not a malfunction.

Be careful of the following conditions when using ;

- TVS diode surface temperature: 110 °C max
- TVS diode clamp peak current: 10Amax

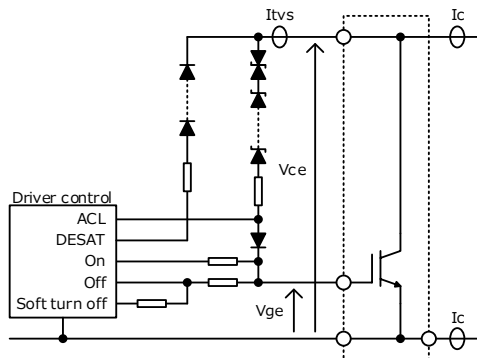

Active clamp gate circuit

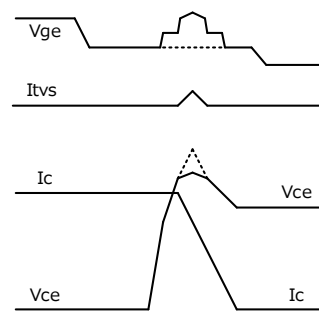

Timing chart of Active clamp function

### 3. Product Connection Instructions, Ambient Environment Instructions, Usage Cautions

#### 3.1 Abnormal input current protection

Always mount fuse on the plus side of input for ensuring safety because the fuse is not built-in the product.  
 Please select the fuse considering conditions such as steady current, inrush current, and ambient temperature.  
 When using a fuse having large rated current or high capacity input electrolytic condenser, by combining another converter and input line and input electrolytic condenser, fuse may not blow off in the case of abnormality.  
 Do not combine high voltage line and fuse.

#### 3.2 VIN- and GND

Although VIN- and GND are insulated inside the product, they are not designed to be insulated according to safety standards.  
 Connect on the set side so that there is no electric potential difference between VIN- and GND.

#### 3.3 Power ON / OFF sequence (VIN+, VCC)

There is no need to consider the power ON / OFF sequence for VIN + and VCC.  
 Since you can input from the common power supply, you can unify the power supply lines.  
 Also, be careful not to turn the signal voltage on when VCC is off, as there is a protection diode between VCC and the signal line.

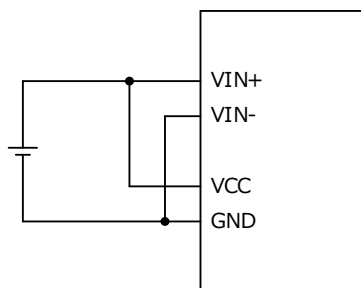

#### 3.4 Mechanical switch

Do not connect mechanical switches to the input line.  
 If a mechanical switch is required, add a rush-prevention resistor in series with the mechanical switch.

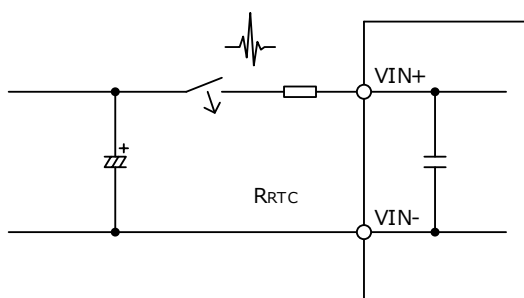



### 3.5 Input signals

Make sure the rise/fall time of the input signal is 500ns or less.

Also, keep input wiring as far as possible from noise sources.

To prevent malfunction due to noise, we recommend the highest possible signal voltage within the recommended range.

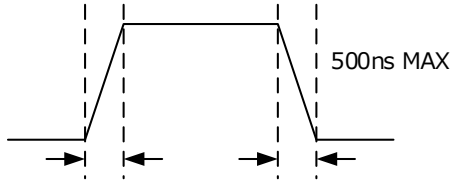

### 3.6 Input cables

Bringing the input cable of the product closer to the main circuit side will cause malfunction due to conduction noise and magnetic flux noise on the main circuit side. Therefore, place the input cable far from where these noises are likely to occur.

If the input cable of the product and the main circuit are close to each other due to space restrictions, we recommend changing the cable to be used to a ribbon cable (stranded wire type) or adding a ferrite core, or both.

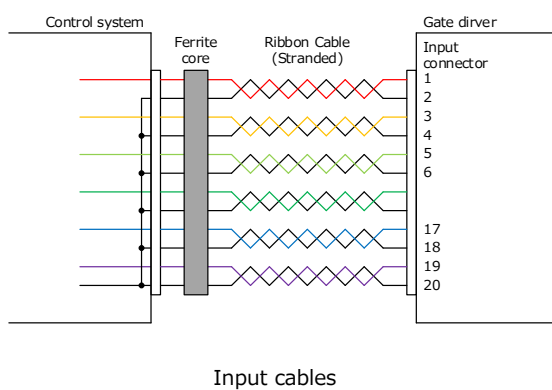
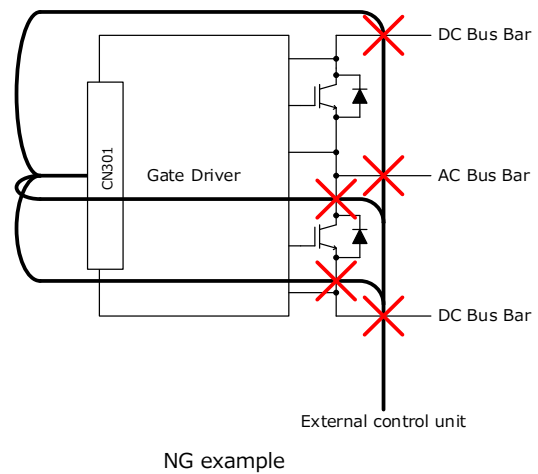
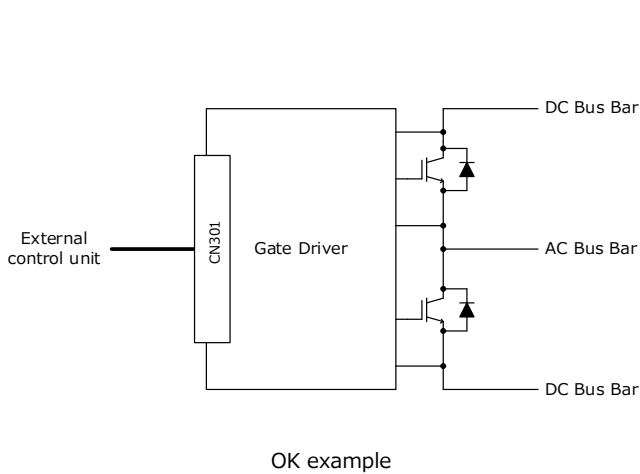

### 3.7 Half bridge mode

The dead time set in half bridge mode is not highly accurate because it is set by the time constant of the capacitor and resistor.

Select direct mode if more accurate operation is required.

### 3.8 Gate resistors selection method

(1) Selecting gate resistors

When selecting a gate resistor, take into consideration surge voltage, noise, etc., of the elements to be connected.

To prevent malfunction of short-circuit protection, select a resistor so that  $t_{VCE\text{FALL}}$  from input signal  $V_{UV\text{LOV}\text{CCH}}$  input until the device collector voltage drops to  $V_{SD}$  or less is less than  $t_{\text{SHORTFIL}}$ .

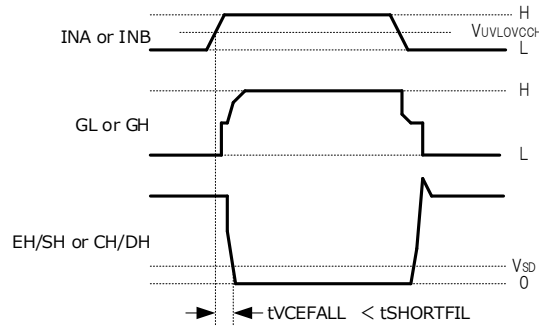

Gate resistors selection timing chart

(2) Maximum electric power and pulse capacity

Since pulse current flows through gate resistors, their pulse power capacity must be fully considered.

For the pulse capacity, contact the relevant resistor manufacturer(s).

The operating electrical power of resistors must be set to around 50% or less of their rated electrical power, and care must be taken for component temperatures during use.

Recommended resistor surface temperature : 120°C or less.

(3) Active clamp (2EG \*\* XD \*\* 1 \* N only)

To assist the active clamping operation, select a resistance value of 240% or more of the internal resistance of the IGBT for the gate resistance on the sink side.

(3) Gate resistor mounting

Mount the lead gate resistor as shown below.

① Axial

- High side gate resistor/ source side : R501
- High side gate resistor/ sink side : R502
- Low side gate resistor/ source side : R521
- Low side gate resistor/ sink side : R522

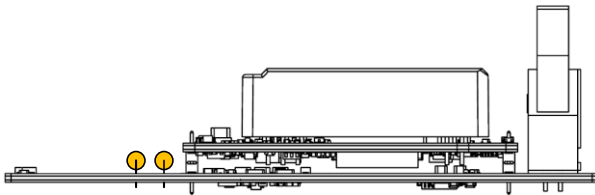
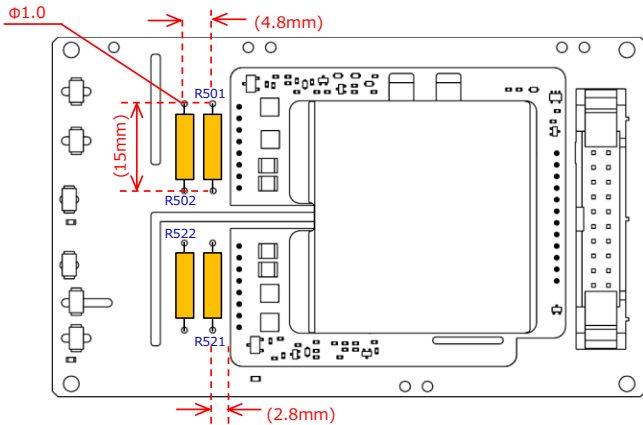

② SMD (Wide terminal type 1.6mm×3.2mm size)

- High side gate resistor/ source side : R301,302,401,402
- High side gate resistor/ sink side : R303,304,403,404
- Low side gate resistor/ source side : R321,322,421,422
- Low side gate resistor/ sink side : R323,324,423,424

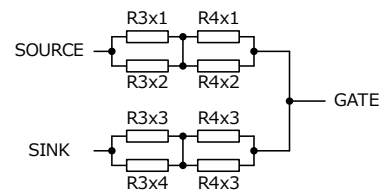
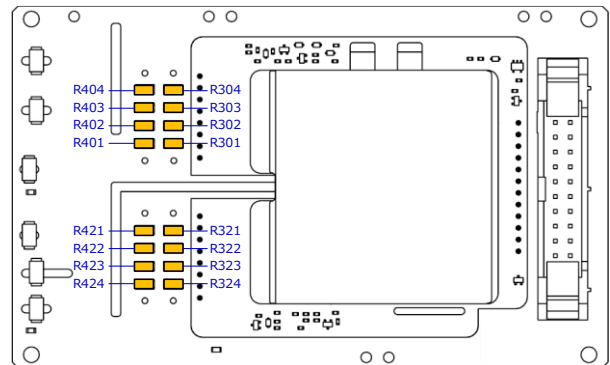

When soldering lead-type gate resistors on your side, be careful that the resistors do not touch the SMD gate resistors patterns.

Or, use a resistor with an insulated surface.

Recommended soldering conditions (Hand work / Pb free) : 390°C(MAX) Less than 3sec

3.9 NTC pin

If necessary, mount the connector in the space below to connect to the NTC of the device.

Recommended soldering conditions (Hand work / Pb free) : 350°C(MAX) Less than 4sec

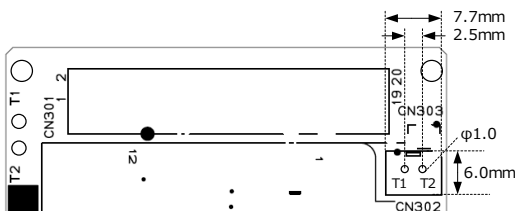

3.10 Product mounting instructions

Please do not apply excessive stress to this product when attaching to power module.

Recommended soldering conditions (Hand work / Pb free) : 350°C(MAX) Less than 4sec

### 3.11 Handling

When handling, do not apply excessive stress to this product.

Do not handle or touch the product in an environment without ESD protection, as it may cause product failure and affect reliability.

### 3.12 Device short circuit

This product has DESAT protection for arm short circuit and load short circuit protection.

However, even if this protection works, the device may be damaged if abnormally high current occurs due to devices characteristics variations or the load short-circuit mode during parallel operation.

To ensure safety, be sure to check the short-circuit current at the unit in which this product is integrated, and evaluate whether it can protect under the condition that there is no damage to the device.

### 3.13 Ambient temperature instructions

The operating ambient temperature of the gate driver should be the temperature inside the set, and measure it as follows.

If heat is generated from a peripheral component, the temperature of the heat should be regarded as the ambient temperature.

If there is no heat-generating component around the gate driver, the temperature at a point that is 20 mm above the center of the gate driver case should be regarded as the ambient temperature.

Use according to the permissible frequency curve described in the data sheet for each product.

Use the gate driver board with a maximum surface temperature of 120 °C or less.

<Point where the ambient temperature is measured if there is a heat-generating component near the module>

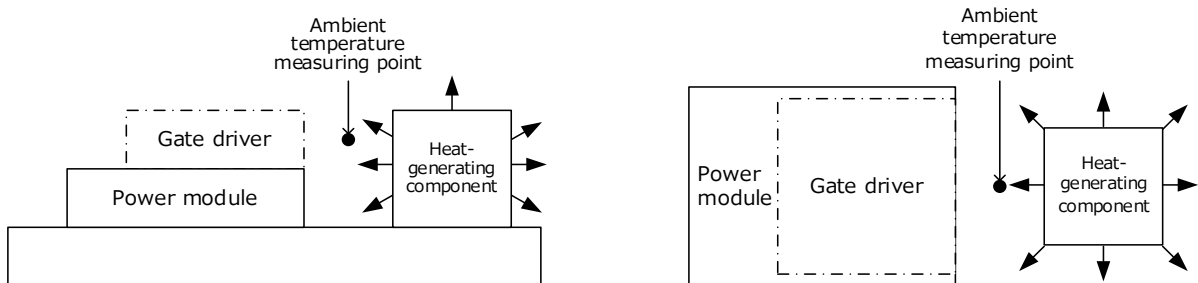

<Point where the ambient temperature is measured if there are no effects of heat-generating components>

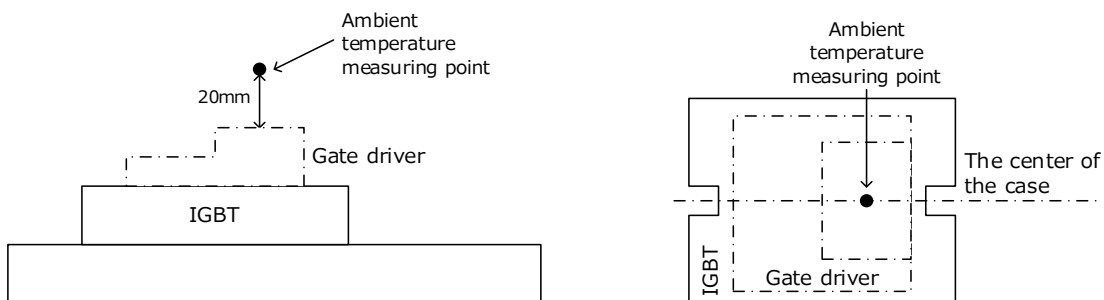

### ■ Important Notice

- This information and product are subject to change without prior notice for the purpose of improvements, etc.  
Ensure that you are in possession of the most up-to-date information when using this product.
- The operation examples and circuit examples shown in this document are for reference purposes only, and TAMURA Corporation disclaims all responsibility for any violations of industrial property rights, intellectual property rights and any other rights owned by TAMURA Corporation or third parties that these may entail.
- The circuit examples and part constants listed in this document are provided as reference for the verification of characteristics. You are to perform design, verification, and judgment at your own responsibility, taking into account the various conditions.
- TAMURA has evaluated the efficiency and performance of this product in a usage environment determined by us.  
Depending on your usage environment or usage method, there is the possibility that this product will not perform sufficiently as shown in the specifications, or may malfunction.  
When applying this product to your devices or systems, please ensure that you conduct evaluations of their state when integrated with this product. You are responsible for judging its applicability.  
TAMURA bears no responsibility whatsoever for any problems with your devices, systems or this product which are caused by your usage environment or usage method.
- TAMURA Corporation constantly strives to improve quality and reliability, but malfunction or failures are bound to occur with some probability in power products. To ensure that failures do not cause accidents resulting in injury or death, fire accidents, social damage, and so on, you are to thoroughly verify the safety of their designs in devices and/or systems, at your own responsibility.
- This product is intended for use in consumer electronics (electric home appliances, business equipment, Information equipment, communication terminal equipment, measuring devices, and so on.) If considering use of this product in equipment or devices that require high reliability (medical devices, transportation equipment, traffic signal control equipment, fire and crime prevention equipment, aeronautics and space devices, nuclear power control, fuel control, in-vehicle equipment, safety devices, and so on), please consult a TAMURA sales representative in advance. Do not use this product for such applications without written permission from TAMURA Corporation.
- This product is intended for use in environments where consumer electronics are commonly used.  
It is not designed for use in special environments such as listed below, and if such use is considered, you are to perform thorough safety and reliability checks at your own responsibility.
  - Use in liquids such as water, oil, chemical solutions, or organic solvents, and use in locations where the product will be exposed to such liquids.
  - Use that involves exposure to direct sunlight, outdoor exposure, or dusty conditions.
  - Use in locations where corrosive gases such as salt air, C12, H2S, NH3, SO2, or NO2, are present.
  - Use in environments with strong static electricity or electromagnetic radiation.
  - Use that involves placing inflammable material next to the product.
  - Use of this product either sealed with a resin filling or coated with resin.
  - Use of water or a water soluble detergent for flux cleaning.
  - Use in locations where condensation is liable to occur.
- This product is not designed to resist radiation.
- This product is not designed to be connected in series or parallel.  
Do not operate this product in a series, parallel, or N+1 redundant configuration.
- Do not use or otherwise make available the TAMURA products or the technology described in this document for any military purposes, including without limitation, for the design, development, use, stockpiling or manufacturing of mass destruction weapons (e.g. nuclear, chemical, or biological weapons or missile technology products).  
When exporting and re-exporting the products or technology described in this document, you should comply with the applicable export control laws and regulations and follow the procedures required by such laws and regulations including, without limitation, Japan -Foreign Exchange and Foreign Trade Control Law and U.S.- Export Administration Regulations.  
The TAMURA products and related technology should not be used for or incorporated into any products or systems whose manufacture, use, or sale is prohibited under any applicable domestic or foreign laws or regulations.
- Please contact your TAMURA sales office for details as to environmental matters such as the RoHS compatibility of product.  
Please use TAMURA products in compliance with all applicable laws and regulations that regulate the inclusion or use of controlled substances, including without limitation, the EU RoHS Directive.  
TAMURA assumes no liability for damages or losses occurring as a result of your noncompliance with applicable laws and regulations.
- TAMURA assumes no liability for damages or losses incurred by you or third parties as a result of unauthorized use of TAMURA products.
- This document and any information herein may not be reproduced in whole or in part without prior written permission from TAMURA.